



## 2553 Three-Phase General Purpose Power Analyzer

The 2553 Power Analyzer incorporates the ideal combination of precision, speed and ease-of-use in an instrument so economical it can be on every bench.

The six-key front panel has four 'soft' keys with menus that simplify the selection of measurements. In addition to numerical results, the 2553 captures wave forms with true 400-point precision. These waveforms can be displayed or directly output at full resolution to a PCL printer. Power and amplitude measurements with a base accuracy of 0.1% are automatically synchronized to the fundamental frequency. Peak measurements of voltage, current and power include continuous, inrush and history modes plus an accumulation mode for W-Hr, A-Hr, and VA-Hr.

### Quality and Reliability

XITRON Technologies, founded in 1990, is the premier source of precision power testing and measurement instruments for industrial manufacturing and medical electronics. Using the latest digital signal processing and circuitry, XITRON's sophisticated technology gives our customers the edge in design verification and product manufacturability. XITRON is ISO-9000: 2000, EN46001 registered and FDA (GMP 820) compliant.

- » Low Cost/High Performance
- » Measures and displays power, frequency, harmonics, THD, CF, K-Factor, Triplens & Inrush
- » Up to 1500 volts peak, 40 amps peak internally & up to 10,000 amps with the use of External Current Transducers
- » DC and 20mHz – 80kHz Frequency Range
- » Graphics Display shows numerical results, waveforms, bar graphs & history plots
- » 16-bit A-D takes up to 220k samples/second
- » Simple 6-key user interface
- » PCL/Text Printer output, IEEE488 interface included
- » 1ø2W, 1ø3W, 3ø3W and 3ø4W configurable using the same wiring

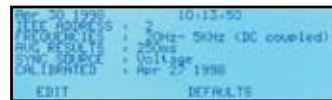

“Soft” keys simplify setup menus



Numeric results can be displayed in large type.



Harmonics shown as bar graphs or listings of values.



See measurements over time such as this voltage history



### XITRON XVIEW Software

While all XITRON precision test equipment is designed to be used in a completely stand-alone manner, there are times when external tools can aid or enhance the operation of an instrument. XView software tools and drivers are designed to help easily configure an instrument from a single screen, or are used to view a complete set of measurements in a single screen. Other XView tools are designed for data collection where results can be recorded in an Excel-compatible file for post-processing, insertion into reports, or simply for archival purposes.

These precompiled applications can be downloaded from the XITRON web site at [www.xitrontech.com/support.html](http://www.xitrontech.com/support.html). Often, XITRON can provide the source code for a particular application, and it can be used as a convenient 'starting point' for a custom software application.



2553

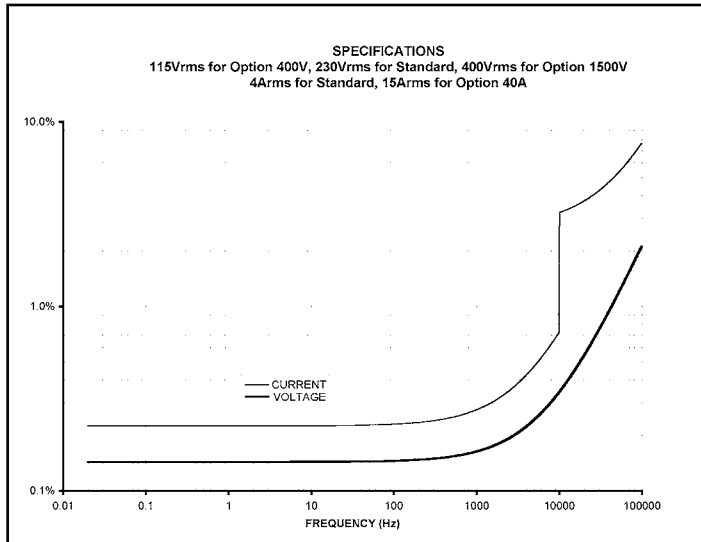

**Voltage & Current Accuracy**

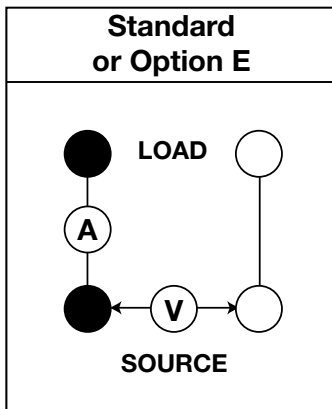

**Input Configuration**

Option	Max Volts	Max Current
-	400V	8A
E	950V	40A
-	1500V	

**Ordering Information**

For Example: To order a base configuration unit that has External Current Transducer capability, can measure Voltages up to 950V peak and can also measure up to 40 Amps peak when configured for Internal then order as follows: 2553 - E - 950V - 40A.

**Condensed Specifications**

(Contact XITRON for complete specifications)

**Voltage: Range**

950Vpk ,400Vpk ,1500Vpk (see ordering information)

**Internal Current: Range**

8Apk ,40Apk (see ordering information)

**External Current Transducers (Option E only)**

Current: Current

Current: 10Arms for 50ms, 2.5Arms continuous, 5Apk measurable

Scaling (In=Out) = +0000.00A = 00.00000A Through +\ -9999.99A = 9999.99A

Current: Voltage

Voltage: 25Vpk for 50ms, 2.5Vrms continuous, 2.5Vpk measurable

Scaling (In=Out) = +0000.00V = 00.00000V Through +\ -9999.99V = 9999.99V

**Resolution**

0.05% of range

**Voltage & Current Accuracy**

(See chart to the left)

**Frequency Measurement**

20 mHz to 80 kHz, 0.01%

**Crest Factor**

Range: 1 to 99

Accuracy: from peak results

**Harmonic & Spectrum Analysis**

Frequency Range: 20 mHz to 50 kHz

Typical accuracy at line frequencies of 50/60 Hz:

THD:0.1%

Harmonic: 0.05%

Phase: 0.1°

**Waveforms**

Actual, Peak Capture and Distortion content

**History**

V&A (rms, peak, envelope, THD), Watts, VAR, PF

User-selectable time base from 400 msec/div to 1 day/div

Resolution 1/20 division

**Physical**

Power input: 12VDC @ 1.5A minimum output

Size: (HxWxD) 4.7" x 13.8"x 9.5" (11.94cm x 35.05cm x 24.13cm)

Weight: 7.5 lbs (3.4 kg)

Operating range: 0°C to 45°C, <85% RH @ 40°C non-condensing

Storage range: -30°C to 65°C <95% RH @ 40°C non-condensing

Unit is supplied with one XITRON Technologies T5 universal

external power supply, 100-240Vrms, 50-60Hz, with a 2.5mm 12VDC output plug

and a three prong IEC320 AC inlet receptacle, plus a three-prong AC power cord.

**Digital Interfaces (standard)**

IEEE488.1: Full talk/listen capabilities

Parallel Printer: IEEE1284, unformatted text or PCL Compatible

**Warranty**

Two years



9770-A Carrol Centre Road | San Diego, CA 92126 | 858.530.8099 phone | 858.530.8077 fax

www.xitrontech.com | sales@xitrontech.com | support@xitrontech.com

Copyright © 2007 - XITRON Technologies, Inc.