

XiTRON TECHNOLOGIES

USER GUIDE

XT560

**Digital
Milliohmmeter**

Warranty

The Xitron Technologies instrument is warranted against defects in material and workmanship for a period of one year after the date of purchase. Xitron Technologies agrees to repair or replace any assembly or component (except batteries) found to be defective, under normal use, during the warranty period. Xitron Technologies' obligation under this warranty is limited solely to repairing any such instrument, which in Xitron Technologies' sole opinion proves to be defective within the scope of the warranty, when returned to the factory or to an authorized service center. Transportation to the factory or service center is to be prepaid by the purchaser. Shipment should not be made without prior authorization by Xitron Technologies.

The warranty does not apply to any products repaired or altered by persons not authorized by Xitron Technologies, or not in accordance with instructions provided by Xitron Technologies. If the instrument is defective as a result of misuse, improper repair, or abnormal conditions or operations, repairs will be billed at cost.

Xitron Technologies assumes no responsibility for its product being used in a hazardous or dangerous manner, either alone or in conjunction with other equipment. Special disclaimers apply to this instrument. Xitron Technologies assumes no liability for secondary charges or consequential damages, and, in any event, Xitron Technologies' liability for breach of warranty under any contract or otherwise, shall not exceed the original purchase price of the specific instrument shipped and against which a claim is made.

Any recommendations made by Xitron Technologies or its Representatives, for use of its products are based upon tests believed to be reliable, but Xitron Technologies makes no warranties of the results to be obtained. This warranty is in lieu of all other warranties, expressed or implied, and no representative or person is authorized to represent or assume for Xitron Technologies any liability in connection with the sale of Xitron products other than set forth herein.

Instrument Serial Number: _____

Document Part Number: MO-560-M Revision A
Print date: September 26, 2006

Copyright

Copyright© 2006 Xitron All rights reserved.

All rights reserved. No part of this publication may be reproduced, transmitted, transcribed, stored in a retrieval system, or translated into any language in any form without prior written consent from Xitron Technologies. This product manual is copyrighted and contains proprietary information, which is subject to change without notice. The product's displays and manual text may be used or copied only in accordance with the terms of the license agreement.



is a trademark of Xitron. All other trademarks or registered trademarks are acknowledged as the exclusive property of their respective owners.

In the interest of continued product development, Xitron Technologies Inc., reserves the right to make changes in this guide and the product it describes at any time, without notice or obligation.

Xitron Technologies Incorporated

Manufacturers of Engineering & Production Test Equipment

9770-A Carroll Centre Rd
San Diego, California 92126 USA

Telephone: (858) 530-8099
Fax: (858) 530-8077

E-mail: sales@xitrontech.com
E-mail: support@xitrontech.com



ISO-9001: 2000
Cert. No. A0001474-1

Contents

INTRODUCTION _____	8
Scope _____	8
Features _____	8
FUNCTIONAL DESCRIPTION _____	10
Front Panel _____	10
Front Panel Display _____	11
Rear Panel _____	12
Dimensions and Stand Operation _____	13
Case Dimensions _____	13
Stand Operation _____	13
Using the Meter _____	14
Range Selection _____	14
HOLD Mode _____	15
Four-Wire Measurement _____	15
CALIBRATION _____	16
LOCAL AND REMOTE OPERATION _____	19
RS-232 / RS-485 Communication Interface _____	19
XT560 Communication _____	19
Pin-out of Communication Port _____	20
Programming Examples _____	20
XT560 RS-232 Communication Commands _____	21
APPENDIX A - PHYSICAL SPECIFICATIONS _____	23
General _____	23
Environment _____	23
Altitude Equivalent _____	23

Dimensions	23
APPENDIX B - MEASUREMENT SPECIFICATIONS	24
Specification	24

Figures

▪ Figure 1. Front Panel _____	10
▪ Figure 2. Rear Panel _____	12
▪ Figure 3. Meter Dimensions _____	13
▪ Figure 4. Stand Retracted _____	14
▪ Figure 5. Standing Position _____	14
▪ Figure 6. Stand as a Handle _____	14
▪ Figure 7. Changing Positions _____	14
▪ Figure 8. Four-wire Measurement Diagram _____	15
▪ Figure 9. Calibration with Resistor Standard _____	18
▪ Figure 10. RS-232 Connector Pin-out _____	20

Introduction

The purpose of this user guide is to describe the use and capabilities of the XT560 Digital Milliohmmeter.

Scope

The XT560 Digital Milliohmmeter is a dedicated, fully automatic instrument that selects the optimal test current, from 100nA to 100mA DC to accurately measure resistances from 10 $\mu\Omega$ to 33M Ω . The XT560 will auto range between 9 ranges, or can be manually set to a fixed range. The XT560 includes a set of Kelvin test clip leads for making four-terminal measurements.

The XT560 is ideal for measuring wiring or cable resistances, windings of motors or generators, lamp filaments, cable splices, wire-to-terminal resistances, heating elements, contact resistance of breakers or switches, connector quality/resistance, fuse resistances, transformers, and grounding connections.

Features

The XT560 Digital Milliohmmeter's features include the following—

- Maximum Display of 33000
- Power Supply 90VAC to 260VAC, 50/60Hz
- Wide Measurement Range: From 10 $\mu\Omega$ resolution to 30M Ω full scale

- High Accuracy $\pm 0.05\%$
- Auto/Manual Function
- RS-232 Interface Standard
- Measurement Speed 10 samples/sec.
- HOLD, REL Function

Functional Description

This chapter describes the operation and interfaces of the XT560 Digital Milliohmmer.

Front Panel

The front panel of the XT560 is shown in Figure 1 below.

FRONT PANEL DIAGRAM

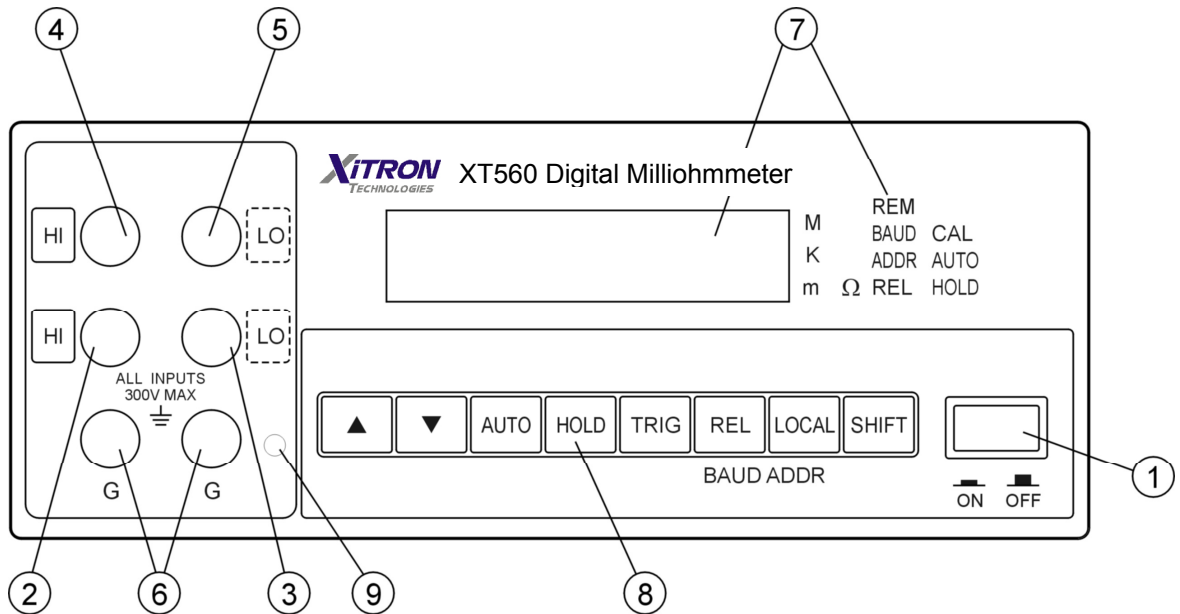

Figure 1. Front Panel

Front Panel Display

Refer to Figure 1.

1. Power push button
2. Source HI Terminal (current output+)
3. Source LO Terminal (current output-)
4. Sense HI Terminal (voltage input+)
5. Sense LO Terminal (voltage input-)
6. G Terminals (ground)
7. The display of the 5601 digital ohm meter is a 6 digit, 0.56 ”, numerical LED display.

The following characters indicate the unit of the value displayed.

M	Mega	1×10^6	ADDR	Address
K	Kilo	1×10^3	REL	Relativr
m	Milli	1×10^{-3}	CAL	Calibrate
Ω	ohm	Resistance	AUTO	Auto range
REM	Remote		BAUD	Baud rate

8. Function Keys

- ▲ key: Up range key
- ▼ key: Down range key
- AUTO key: Auto range key
- HOLD key: Touch hold key
- TRIG key: Trigger a data key
- REL key: Relative mode key

9. CAL Button: To enter into the calibration mode.

Rear Panel

Refer to Figure 2.

1. RS-232 Connector
2. Power-Line Cord Connector, AC, 90~264V, 50/60Hz
3. Fuse for power, 250V/1A
4. Fuse for input, 250V/0.5A

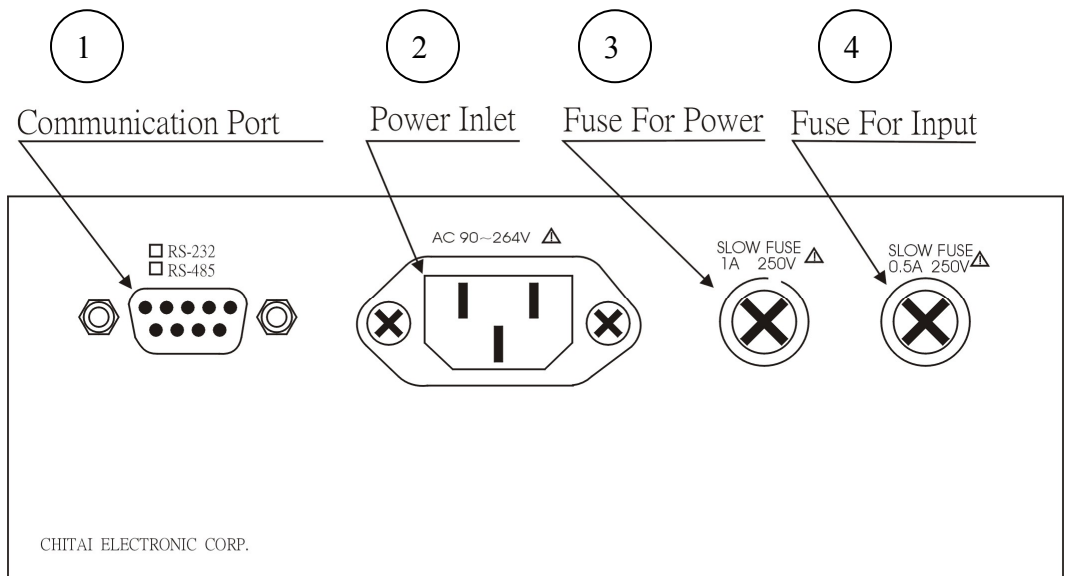

Figure 2. Rear Panel



Replacement fuses must be the same size as the original.

Dimensions and Stand Operation

Case Dimensions

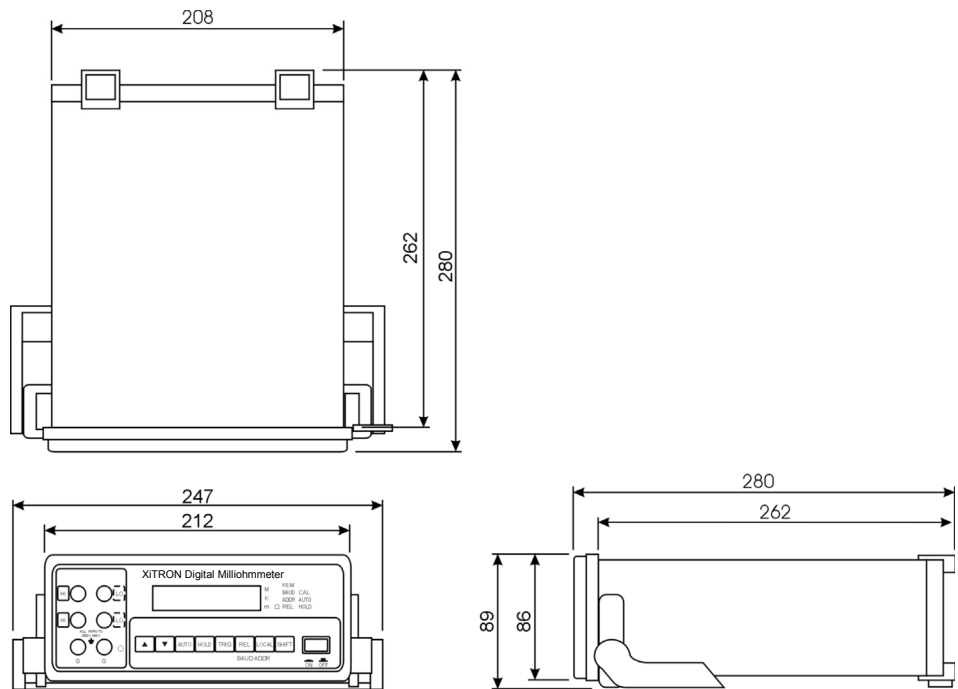

Units: mm

Figure 3. Meter Dimensions

Stand Operation

There are 3 positions for the XT560 stand. Figures 4, 5, and 6 illustrate the XT560 with the stand fully retracted horizontally, as a stand, and as a handle. Figure 7 illustrates the method of changing the position of

the stand. Pull the stand with both hands from the left and right sides, turn it to the desired position, then release.

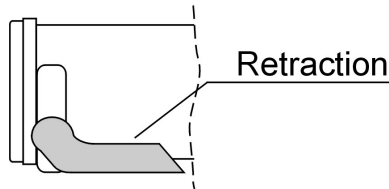

Figure 4. Stand Retracted

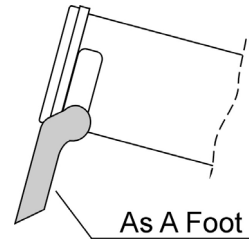

Figure 5. Standing Position

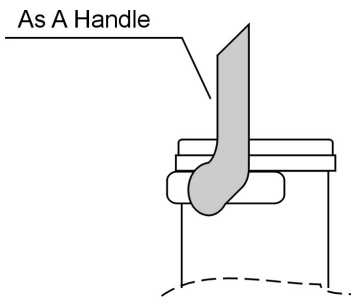

Figure 6. Stand as a Handle

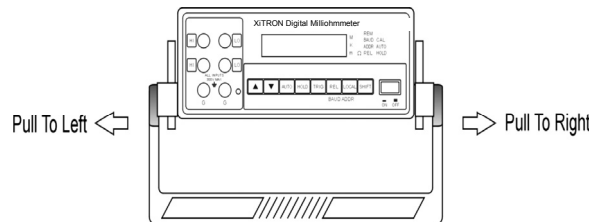

Figure 7. Changing Positions

Using the Meter

Range Selection

The XT560 digital milliohmmeter has two ranging modes, Manual and Auto. The measurement range can be selected using either auto range by pressing the Auto button, or Manual range by pressing the ▲ or ▼ buttons.

In auto range, the ohmmeter changes to a higher range when the reading is over full scale (30000 counts), and changes to a lower range

when the reading is below 9% of full scale (2700 counts). The auto range function will range from the highest range, 30Mohms, to the lowest range, 300mohms.

The XT560 measures from 10 μ ohms to 30Mohms in 9 ranges. The ranges are: 300mohms, 3ohms, 30ohms, 300ohms, 3kohms, 30kohms, 300kohms, 3Mohms, and 30Mohms .

HOLD Mode

When the XT560 is operating in the display hold mode, pressing the HOLD key allows the user to take a measurement and hold that measurement value on the display. Press the HOLD key again to remove the hold function.

Four-Wire Measurement

The XT560 makes 4-wire resistance measurements as shown in Figure 8. The source HI and LO leads apply a known, internal current source to the unknown resistance, the sense HI and LO leads measure the voltage across the unknown resistance.

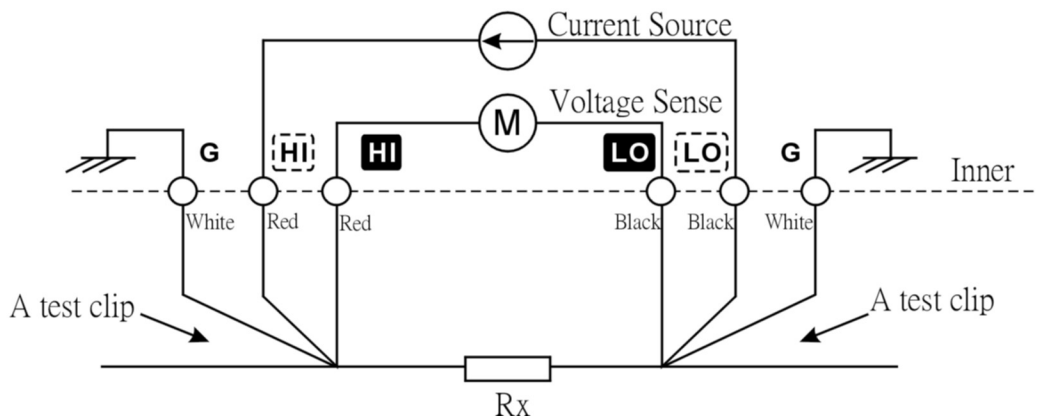

Figure 8. Four-wire Measurement Diagram

CALIBRATION

To perform a calibration, proceed as follows:

1. Press the CAL enable button to enter the calibration mode.
2. Press the UP-DOWN button to select the range to be calibrated.
3. Short the probes together and wait a minimum period of time as specified in Reference Table 1. Then press the SHIFT and TRIG keys at the same time.
4. Connect the Resistor Standard to the meter in a 4-wire configuration, refer to Figure 9. Wait for a period of time as specified in Reference Table 1, for the XT560 to stabilize. Then press the SHIFT and HOLD keys at the same time.
5. Repeat this procedure adjusting the XT560 milliohmmeter for each range: 300m Ω range, 3 Ω range, ... and finally the 30M Ω range.

Reference Table 1

RANGE	RESISTOR STANDARD VALUE	WAITING TIME BEFORE PRESSING KEYS	PRESS KEY
300m Ω	0 Ω	5 sec ...	SHIFT+TRIG SHIFT+HOLD
	100m Ω		
3 Ω	0 Ω	3 sec ...	SHIFT+TRIG SHIFT+HOLD
	1 Ω		
30 Ω	0 Ω	3 sec ...	SHIFT+TRIG SHIFT+HOLD
	10 Ω		
300 Ω	0 Ω	3 sec ...	SHIFT+TRIG SHIFT+HOLD
	100 Ω		
3K Ω	0 Ω	3 sec ...	SHIFT+TRIG SHIFT+HOLD
	1k Ω		
30K Ω	0 Ω	3 sec ...	SHIFT+TRIG SHIFT+HOLD
	10k Ω		
300K Ω	0 Ω	3 sec ...	SHIFT+TRIG SHIFT+HOLD
	100k Ω		
3M Ω	0 Ω	5 sec ...	SHIFT+TRIG SHIFT+HOLD
	1M Ω		
30M Ω	0 Ω	10 sec ...	SHIFT+TRIG SHIFT+HOLD
	10M Ω		

Note: **DO NOT** enter the adjustment mode if the Resistor Standard and a certified technician are not available.

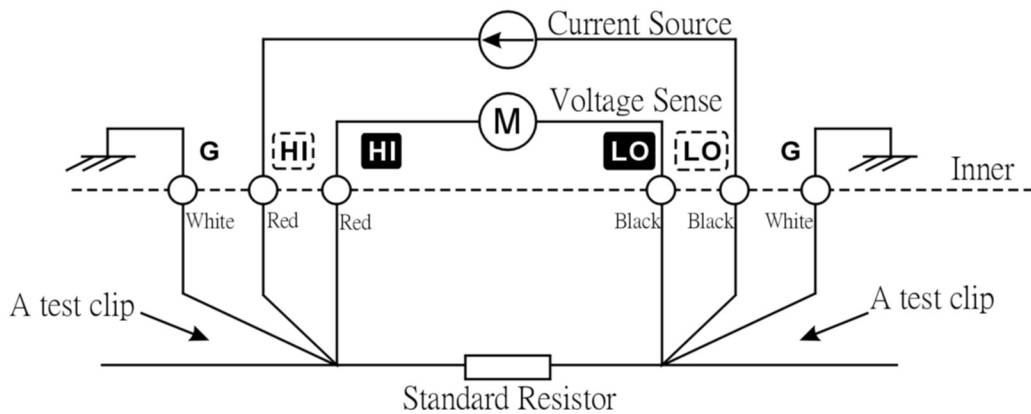

Figure 9. Calibration with Resistor Standard

LOCAL AND REMOTE OPERATION

When the meter is operated from a host computer it is said to be operated “remotely”. When the meter is operated from its front panel, it is said to be operated “locally”. Some operations, such as setting the communication parameters for the RS-232 interface, can only be performed from the front panel .

To change the baud rate, perform the following. Press and hold the SHIFT key, then press the REL to display the present communication rate. At this point, while holding the SHIFT key, additional presses of the REL key will select new baud rates.

RS-232 / RS-485 Communication Interface

XT560 Communication

Baud rates supported: 300, 2400, 9600

Parity: None

Number of data bits: 8 bits

Number of stop bits: 1 bit

Address: 0 to 30

Echo: On/off

Pin-out of Communication Port

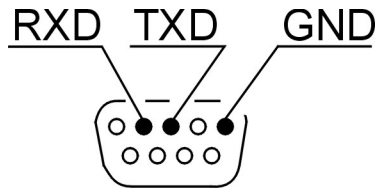

Figure 10. RS-232 Connector Pin-out

Programming Examples

Visual Basic example:

```
Private Sub Command1_Click()  
    'send command to XT560  
    MSComm1.Output = "VAL ?" & Chr(13)  
  
    'delay 1 second to read XT560  
    Timer1.Enabled = True  
End Sub  
  
Private Sub Form_Load()  
    'set serial port  
    MSComm1.InputMode = comInputModeText  
    MSComm1.Settings = "9600,n,8,1"  
    MSComm1.CommPort = 1  
    MSComm1.PortOpen = True  
  
    'set timer to delay 1 second  
    Timer1.Enabled = False  
    Timer1.Interval = 1000  
End Sub
```

```

Private Sub Timer1_Timer()
    Timer1.Enabled = False

    'read XT560 data
    Text1.Text = MSComm1.Input
End Sub

```

XT560 RS-232 Communication Commands

COMMAND	FUNCTION
HOLD	Pressing the hold key stops a measurement. HOLD is indicated when the lamp is on.
HOLDCLR	Meter exits HOLD mode and display returns to normal operation.
REL	Meter reads resistance as a relative value. In REL operation, auto-range is disabled.
RELCLR	Meter exits the relative mode and returns to auto-ranging.
VAL ?	Meter returns the value shown on the display. Example format: +1.23456+0 OHMS(CR)
TRIG	Trigger a data reading.
ECHO1	Echo on.
ECHO2	Echo off.
AUTO	Causes the meter to enter the auto-ranging mode on the display .

RANGE < >

Sets the display to the range, from 1 to 9, as shown in the table below.

Range Value	Ohms range
1	300mΩ
2	3Ω
3	30Ω
4	300Ω
5	3kΩ
6	30kΩ
7	300kΩ
8	3MΩ
9	30MΩ

Appendix A - Physical Specifications

General

Note: Specifications subject to change without notice.

Environment

Operating: 0°C to 50°C, <80%RH non-condensing
Storage: -20°C to 70°C, non-condensing.

Altitude Equivalent

Atmospheric pressures and air densities from 1000ft below sea level to 15000ft above sea level.

Dimensions

247mmW × 89mmH × 280mmD

Appendix B - Measurement Specifications

Specification

Maximum Reading	33000
Sampling Rate	10 samples/sec
Display	6-digit, 7-segment LED, 14.2mm high
Over Range	“00000” flash
Range Selection	Automatic and Manual
Overload Protection	AC 330Vrms
Power Supply	AC 90~264V, 50/60Hz, <15VA
RS-232	Baud rates 300, 2400, 9600, No parity, one Stop bit

Range	Test Range	Resolution	Test Current	Accuracy
300.00mΩ	0.01mΩ~330.00mΩ	10μΩ	DC 100mA	±0.05% ± 20digits
3.0000Ω	0.0001Ω~3.3000Ω	100μΩ	DC 100mA	±0.02% ± 10digits
30.000Ω	0.001Ω~33.000Ω	1mΩ	DC 10mA	
300.00Ω	0.01Ω~330.00Ω	10mΩ	DC 1mA	
3.0000kΩ	0.0001kΩ~3.3000kΩ	100mΩ	DC 1mA	
30.000kΩ	0.001kΩ~33.000kΩ	1Ω	DC 100μA	
300.00kΩ	0.01kΩ~330.00kΩ	10Ω	DC 10μA	
3.0000MΩ	0.0001MΩ~3.3000MΩ	100Ω	DC 1μA	
30.000MΩ	0.001MΩ~33.000MΩ	1kΩ	DC 100nA	±0.05% ± 20digits